

## **AXIPAL BZI**

**Series: MA sizes 400 to 1250**  
**VA - VR sizes 355 to 1600**

## YOUR VENTILATOR

You have just acquired an AXIPAL BZI motorised fan unit. As with all rotating machinery, when installing, starting up, using and maintaining this equipment you must take certain essential yet simple safety precautions.

Please spend a few minutes reading over the various chapters of this User Manual.

Our teams have taken the greatest care in the production of your AXIPAL BZI. If, however, a component appears defective or if you have need of advice or technical support, our experts are entirely at your disposal:

**Fläkt Solyvent-Ventec**  
**Support Department**  
**Tel.: +33.472.45.13.00**

## CONFORMITY WITH MACHINERY DIRECTIVE 98/37/CE CONFORMITY WITH ELECTROMAGNETIC COMPATIBILITY DIRECTIVE 89/336/CE

As French representatives of the profession of industrial ventilator manufacturers, Uniclimate's ventilation division, taking into consideration the terms of the Council Directive of the 14<sup>th</sup> June 1989 concerning the homologation of member state legislation relating to machinery (98/37/EC) – in turn modified by Directives 97/368/CE and 93/44/CE, notes that:

### **Industrial Motorised Fans:**

- are machinery
- are designed to be integrated into machinery, into a system or assembly or to be assembled with other machinery to make up a machine (in the sense of the directive).
- Cannot enter service before the machine into which it has been incorporated and as such are not declared to conform with the instructions laid down in Directive 98/37/CE and the national legislation this directive transposes.
- Cannot thus bear the CE marking.
- But must be accompanied by a manufacturer's declaration (Appendix IIB of Directive 98/37/CE).

Industrial motorised fans, as defined by Directive 89/336/CE, are not electrical or electro-magnetic devices, neither can they be said to be installations or equipment. Rather they are components, designed to be integrated into the make up of a piece of equipment. As such they are not designed for a specific 'end use' in their 'as-supplied' state. Therefore they are not subject to Directive 89/336/CE nor to the CE markings covered.

The declaration of incorporation for this machine is attached to the delivery note.

## SAFETY INSTRUCTIONS

### Integration of the fan into a machine or installation

The machine or installation into which the fan is to be integrated must complement the safety measures built into the fan itself in order to satisfy the totality of the requirements laid down in the Machinery Directive.

Standard EN14461 – Industrial Ventilators – Safety Requirements defines, in particular, the risks inherent specifically in the use of ventilators and gives recommendations and means for the reduction of these risks.

It is the responsibility of the installer to ensure that, prior to starting the fan, the installation meets the obligations imposed by this standard, in particular concerning the protection of personnel.

### Operating personnel

Any machine must only be handled, installed and operated by qualified, authorised personnel.

### Conditions of Use

The conditions of use applicable to the material, as laid down in the original contract, include, for example:

- The nature and/or temperature of the fluid to be transported.
- Rotational speed

must not be modified unless Fläkt Solyvent-Ventec has been consulted.

To obtain the acoustic pressure (noise) levels required by the site an in-depth and complete understanding of the latter is required, a task that remains the responsibility of the purchaser. The level can be calculated using the acoustic pressure levels indicated in our offer.

If a speed regulating device is used, it is imperative that the maximum speed indicated on the manufacturer's plate on the machine (and in the 'Your Ventilator' chapter of this manual) is not exceeded.

### Inspection.

The ventilator must always be stopped and locked out prior to all inspection operations. You must wait for any potential hot zones (motor casing, bearings, casing – if the fluid being moved is hot) have had the time to cool sufficiently before starting any operation.

## HANDLING

Handle the ventilator with care using appropriate, suitable handling equipment: forklifts, pallet trucks with suitable forks, lifting equipment with a sufficiently high load capacity.

To do this you must either use the pallet supplied with the ventilator or the lifting rings designed with this in mind.

If at all possible you should use flexible slings with a sufficient load-bearing capacity and long enough to allow the ventilator to be moved horizontally as far as possible.

It is possible to use the lifting rings on the motor in addition to those on the ventilator to improve the handling positioning.

To avoid risks, you should, before any handling operation, check the weight of the ventilator unit, as indicated on the manufacturer's ID plate and in the 'Your Ventilator' chapter of this manual. This weight corresponds to the weight of the ventilator with all its accessories fitted, as delivered.

### Never attempt to lift the ventilator:



- using the motor lifting rings
- using unused holes in the casing/stand
- By its turbine wheel
- By the inlet flange and/or exhaust framework
- by one of its accessories

## SHORT TERM STORAGE (LESS THAN 3 MONTHS)

If the ventilator is to be stored between it being delivered and installed, it must be warehoused in a temperate, protected area with a low relative humidity. First you must blank off the inlet and exhaust holes to stop any objects accidentally infiltrating the interior of the casing (possibly damaging the turbine wheel, or, at the very least, unbalancing it).



**The ventilator must always be stored in its operational orientation.**

## LONG TERM STORAGE (MORE THAN 3 MONTHS)

A certain number of additional precautions must be taken for long-term storage.

Concerning the motor, the following information is for information only; see the manufacturer's technical manual for details.

The turbine must be periodically turned over by hand to ensure the bearing grease on the motor is correctly distributed.

If this is not possible, you should, during the installation:

- Replace the motor bearings before use if they are 'lubricated for life'.
- Degrease the motor bearings completely and apply fresh grease if the bearings are fitted with nipples.

The motor purge holes, which may be covered by plugs, must be opened to allow the coils to 'breathe' and avoid a build-up of humidity.

We would recommend that, before starting up, you test the insulation resistance of the coils in accordance with the manufacturer's technical manual to ensure there is no residual humidity present – likely to damage the motor.

### **Accessories supplied with the ventilator (applicable with reference to optional equipment chosen):**

Flexible sleeving: Unfold prior to storage to avoid marks and avoid the risk of tearing during assembly.

Silencers: These are fitted with a purge valve to allow humidity to drain away from the soundproofing. When storing, ensure that the purge valve is open and at the lowest point on the silencer.

Inlet filter: Remove the filter cartridge and store in leak tight packaging, well away from any humidity.

Other optional equipment: See Manufacturer's Technical Manual.

## INSTALLATION

### **Foundations, installation mounts**

The preparation and construction of the foundations is the sole responsibility of the purchaser.

These foundations may vary from the simplest, floor-mounting systems to the most complex high-level structures.

To fix to the ground, the most generally used solution is a simple solid concrete foundation. This should have a perfectly flat surface to avoid stressing the structure of the ventilator, stresses that might develop into abnormal, potentially damaging, vibrations.

For all other mounting methods, the installer must take into consideration the risks of resonant frequencies in the load bearing structures and the transmission of vibration into the surroundings.

To reduce the risk of resonance developing, we would recommend that the lowest resonant frequencies of the load-bearing structure should correspond to a frequency of at least 40% higher than the maximum speed of the ventilator itself. To reduce the risks caused by the transmission of vibrations, we would recommend that the unit be mounted on sprung blocks. The calculations for these mountings must take into consideration the mass of the ventilator with its accessories as well as its rotational speed.

### **Connections to Ductwork**

In all circumstances (rigid or flexible sleeve connections) you must align the ducts perfectly with the ventilator's interfaces. The ventilator should never be required to support the weight of the ductwork. The latter must have its own, dedicated supports/mountings.

Under no circumstances should you use the mounting bolts to 'pull' the ductwork onto the ventilator. You must reduce the residual play between the ductwork and the unit's flanges/framework to an absolute minimum prior to assembly.

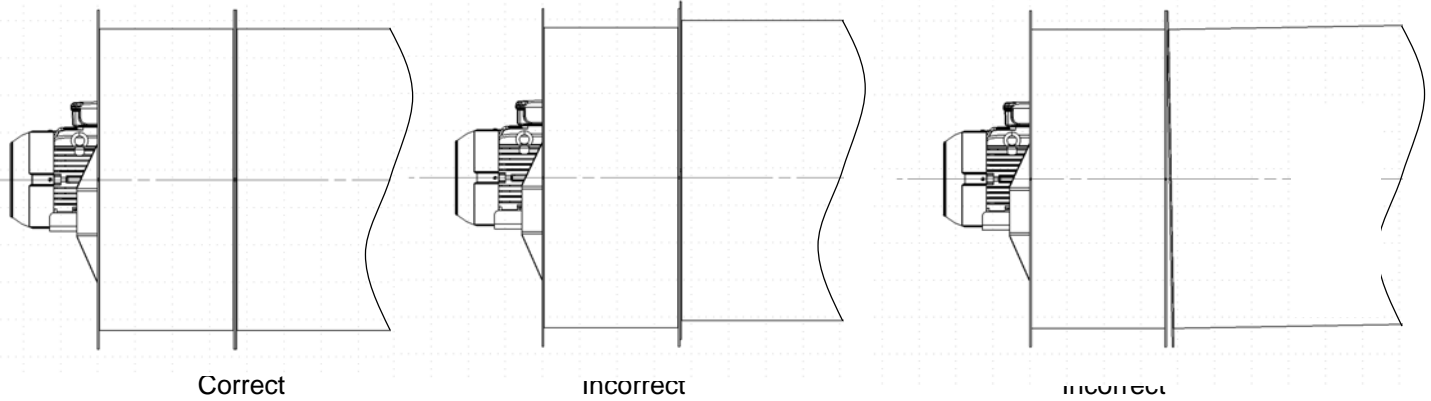

If sprung-mounts are used or if the unit is to operate in temperatures likely to cause dilations, you must use flexible sleeves.

The latter are designed to reduce vibration being transmitted through the ductwork and thus onwards through the surroundings.

To avoid tension of the sleeves, the distance between the flange or frame on the ventilator and its connector duct must be 10 to 15 mm less than the nominal length of the flexible sleeve itself.

### Protecting against mechanical hazards

Protection against mechanical hazards requires that inlet and exhaust grilles are fitted to the ventilator if it is not directly connected to ducts.

Any failure to order an inlet or exhaust grille presumes that the ventilator will be connected to a duct and as such is the responsibility of the purchaser.

### Protecting against electrical hazards

The ventilator itself is not fitted with an electrical power disconnecting device for use as an emergency stop or to electrically 'lock-out' the equipment.

These additional devices, to be integrated into the electrical supply system, are the responsibility of the purchaser.

### Protecting against thermal hazards

Under normal operating conditions, certain of the ventilator's components are likely to achieve surface temperatures of above 70°C.

These parts include the motor casings, bearing housings and the ventilator casing itself if hot fluids are being processed.

It is the responsibility of the installer to define an appropriate safety perimeter around these components and to display the regulatory notices to avoid the risk of contact by personnel in the vicinity.



**Never insulate or encase the motor and bearing housings.  
This will interfere with cooling and thus cause premature wear/destruction of the component.**

## COMMISSIONING

### Before turning over

With the ventilator installed in its final configuration, its interfaces connected and the electrical connections made, you must carry out the following checks prior to starting up the ventilator.

- Check that the mounting bolts are tightened correctly.
- Check that the connecting bolts are tightened correctly.
- Check that the motor connections are tightened.
- Turn the turbine over by hand and check that there is no friction and/or interference with the rotating elements.



**On new, guaranteed equipment, never adjust or disassemble without the prior written authorisation of our Support Department.  
If this is not received, any work will annul the contractual guarantee on the equipment.**

## First running

When running the ventilator for the first time, you should immediately check to ensure that the turbine is rotating in the right direction (indicated by an arrow engraved into each blade).

If the turbine is turning the wrong way, stop the unit immediately and invert two of the three motor supply cables to re-set the direction of rotation.



**If using with a variable frequency device (VFD), check the technical notice supplied with the device before inverting any cables. On certain types of variation devices, the phases must be identified to ensure that the safety measures and/or magnetic flux optimisation, is working.**

## Verifications once running

These tests are used to ensure that your ventilator is running correctly and to identify any potential problems related to its installation.

- Measure the current upstream of the motor and compare this with the rated amperage on the motor's ID plate. If the measured value is clearly higher, the fan should be shut down immediately. If the value measured is clearly lower, check the rotational speed of the fan.
- Measure the rotational speed of the turbine. If the measured value is higher than the maximum speed given on the ID plate, shut down the ventilator immediately.
- Measure the speed of vibrations in three axes on each motor bearing. In accordance with EN 14694, the values obtained must be less than or equal to the following limitations:
  - **Rigid mountings: 4.5 mm/s**
  - **Flexible mountings: 6.3 mm/s**



On new equipment, covered by a guarantee, if any one of the aforementioned tests is failed you must immediately contact our Support Department.

## Verifications after running-in

As with all equipment fitted with mechanical components, your ventilator will require a running-in period to stabilise its performance.

The verifications we recommend below must be carried out after this period. Record and keep the results to use as a reference for future diagnostics or as part of a preventive maintenance plan.

The running-in periods of a Type BZI ventilator is estimated at 4 hours, the time required for the motor to reach thermal equilibrium. However, this period may need to be extended – depending on the system within which the ventilator is used given the fact that the system itself must reach equilibrium before the tests are truly representative.

- Measure the line current upstream of the motor. The reading obtained may be greater than that measured during the post start-up test but should under no circumstances exceed the value shown on the motor plate.
- Measure the temperature of the motor casing. Repeat this measurement after one hour. At a constant ambient temperature, the temperature of the casing should not increase by more than 2°C.
- Measure the speed of vibrations in three axes on the motor bearings. The readings obtained must remain less than the criteria laid down in the previous chapter and must not have increased by more than 15% over those recorded during the start-up tests.



**A failure of one of the aforementioned tests may be due to either a malfunction or an incorrect installation. Contact our Support Department, with these results, for a more accurate diagnostic.**

## MAINTENANCE

Depending on the use the ventilator is put to, maintenance work may be curative, preventive or conditional. It is the responsibility of the user, depending on operational requirements and accessibility, to define maintenance policies.

The recommendations given below are for information only – for standard, industrial use. The periods between maintenance may be adjusted to cope with the precise conditions of use of the ventilator.

Our Support Department can provide further assistance in the choice of maintenance policies to be implemented.

### Preventive maintenance

Periods	BZI VA-VR-MA
5000 hours or 1 year  SERVICE 1	Clean & Inspect turbine wheel  Check vibration levels  Check motor current.
20000 hours or 4 years  Operations are supplementary to those above.  SERVICE 2	Verification of motor insulation resistance levels.  <i>* Replace motor bearings</i>

\* Italics = Applicable only in the absence of manufacturer's instructions.

### Conditional maintenance

It is possible, by monitoring certain parameters, to delay having to carry out certain motor bearing lubrication and replacement operations until the condition of the components themselves actually justify their replacement.

We thus list, for information, certain possible monitoring methods and thresholds to be applied to a ventilator being used for standard industrial use. These measures may be modified with regard to the type of use and system surrounding the ventilator.

#### Monitoring the temperature of the motor bearings :

The bearings can, on request, be fitted with a temperature sensor to provide constant monitoring of their internal temperatures.

- If this internal temperature increased by more than 10°C in less than one hour at a constant ambient temperature, the equipment must be shut down and locked-out. Change the bearing in question.
- The internal temperature tends to increase slowly over time. When it rises to a level of greater than 10°C higher than the temperature recorded for the machine when new (after running-in), top up the lubricant. If, after re-starting, the temperature does not drop to a level close to that of a new machine, the bearings should be replaced.

#### Monitoring motor bearing vibration speed:

The bearings can, on request, be fitted with accelerometers used to provide continual monitoring of vibration levels.

- If the level of vibration suddenly varies through an amplitude of more than 15% of the level recorded when new, shutdown the ventilator and check:
  - The condition of the transmission belts,
  - The condition of the drive shaft and motor bearings,
  - The presence of balance weights on the turbine wheel.

Replace any damaged component.

- Due to wear on rotating components, the vibration levels will tend to rise over time. When the level reaches that defined by ISO 14694 as an alarm threshold, schedule a SERVICE 2 as soon as possible. The alarm thresholds are:
  - **7.1 mm/s for a rigid installation**
  - **11.8 mm/s for flexible mountings**



For safety reasons, shut-down and lock-out the ventilator if the vibration levels on any one of the bearings exceeds:

- 9 mm/s for a rigid installation
- 12.5 mm/s for flexible mountings

## INTERVENTIONS INVOLVING THE VENTILATOR



During the guarantee period, only those personnel employed by our Service Department are authorised to work on the ventilator. Once this period has passed, we would recommend that you leave any interventions to our Service Department, who have the necessary technical skills to ensure that any work is successfully completed.

All work described below is based upon a securely locked-out ventilator with its electrical connections disconnected to eliminate any risk to the personnel involved.

The exhaust and inlet holes are presumed to be accessible.

### Cleaning and Inspecting the Turbine Wheel – VA Arrangement – Access via an inspection hatch fitted to the shell

- Remove the inspection hatch on the shell.
- Clean the turbine, one blade at a time – turning it by hand. Never use solvent cleaners – this risks damaging the coating. Never spray liquid into the space – this will build up in the base of the shell.
- Then carry out a visual inspection of each blade – checking that there are no cracks or splits.
- Check the appearance of each half-wheel trim. Check that the balance weights are present.
- Refit the inspection hatch.

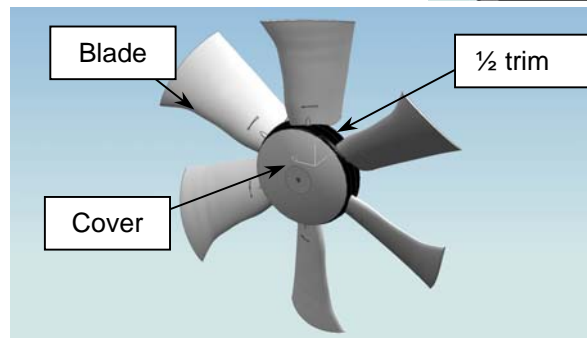
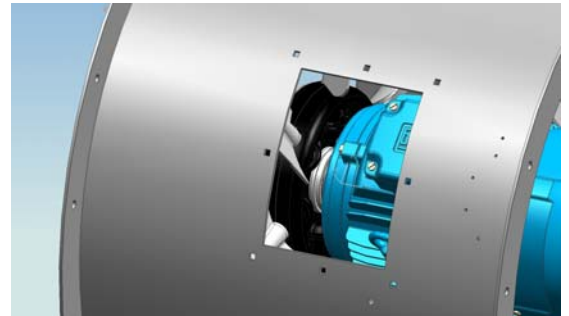

### Cleaning and inspecting the wheel – Arrangements VR and MA

This concerns ventilators with a short-body shell without an inspection hatch. These ventilators are, in the main, installed with open inlets or exhaust, fitted simply with a protective grille.

- Remove the protective grille.
- Carry out the cleaning and verification operations described in the above paragraph.
- Refit the grille.

## Removal and refitting of the turbine wheel

The removal of the turbine wheel is an exceptional operation in the life of a ventilator. Nevertheless, certain applications may require the periodic replacement of the turbine wheel.



**Removing a turbine wheel by heating its hub will require it to be replaced.**

- Remove the shaft-end fixings and turbine rain cover.
- Remove the shaft-end bolt and washer.
- Turbine wheel with machined hub: The visible face of the hub has two threaded, M6, M8 or M10 holes (depending on the size of the device). Use a thread extractor to disconnect the turbine wheel from its shaft.  
If it sticks, spray on a releasing agent, leave for a couple of minutes and repeat the operation.
- Turbine wheel with conical cap: Remove the two cap-holding screws. Refit them on the two holes on the front face of the hub to offset the turbine wheel.
- To refit the wheel, repeat the operations in reverse order, being careful to align the slot on the cap or hub with the key on the shaft.
- Fit the rain-cover, the washer and shaft-end screw.

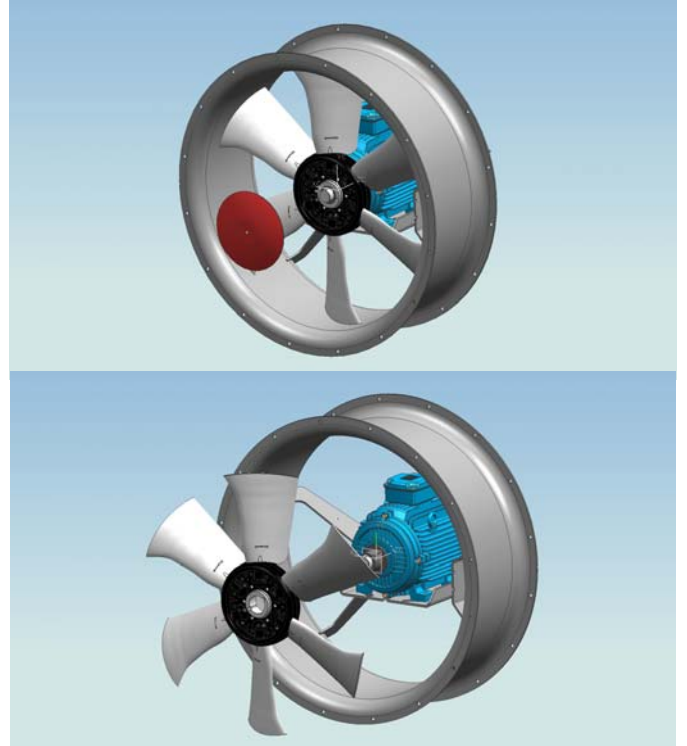

**Returning the ventilator to service after the wheel has been replaced requires the same test procedures as used during the installation and commissioning of a new machine.**

## Removing and Refitting the motor

With the wheel removed:

- Remove the motor screw fixings
- Lift the motor slightly using its lifting rings and pull it back to free it from the shell.

The re-fitting operation is achieved by repeating the above operations in reverse order.

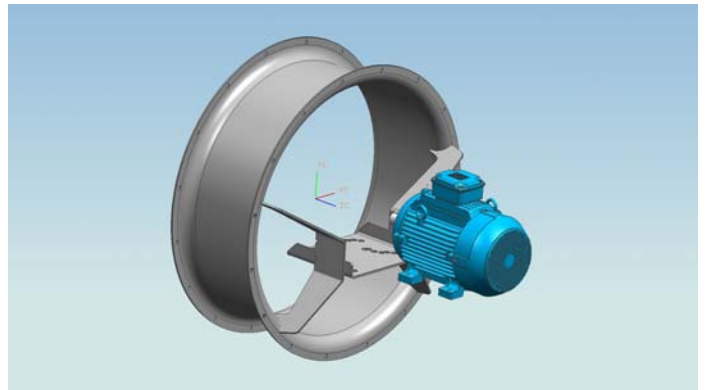

# Axial BZI VA-VR-MA Ventilators – Component Parts List

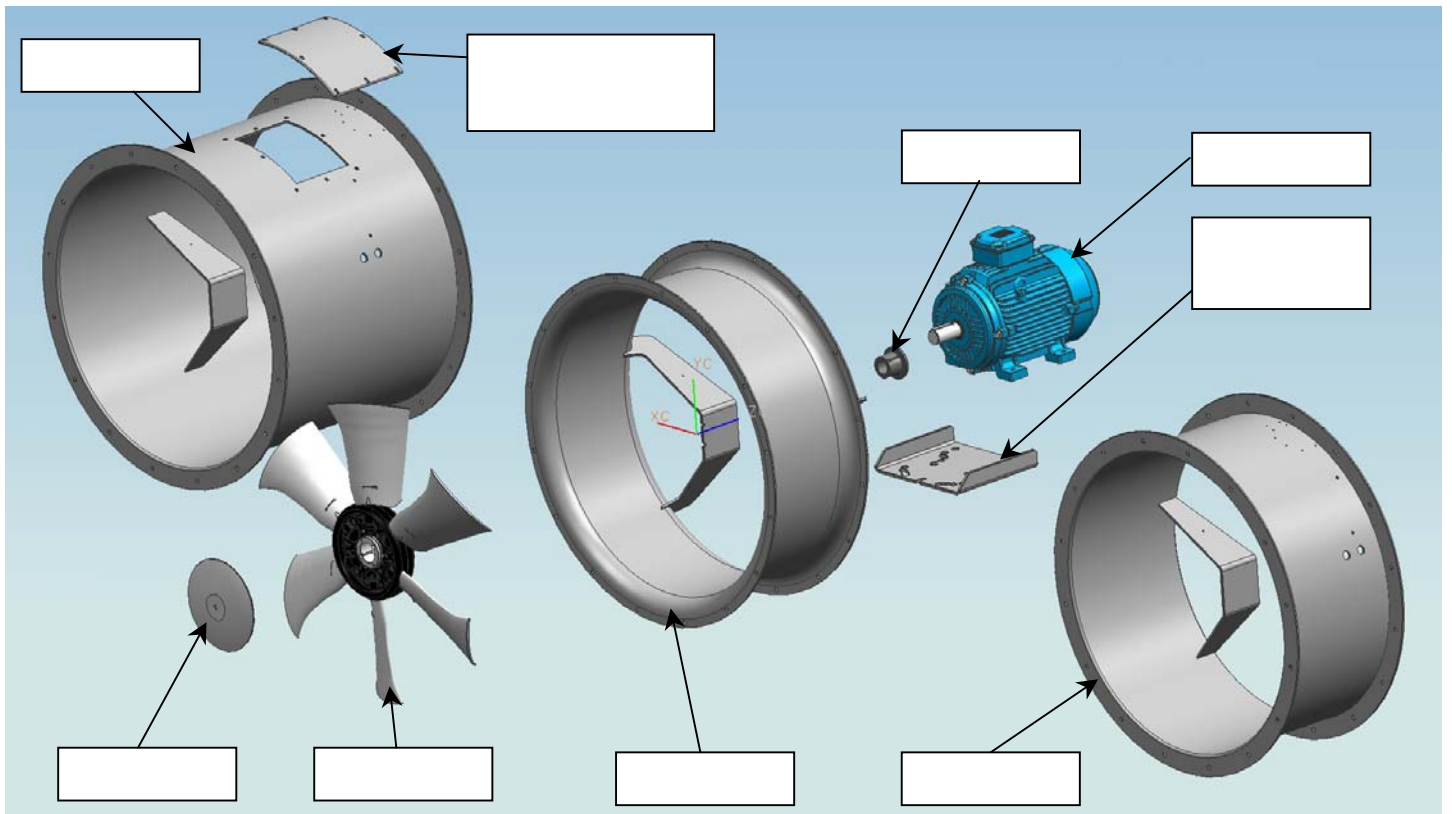

## ACCESSORIES

### Silencers

The soundproofing equipment can progressively clog up with particles and/or humidity – thus reducing its efficiency. It must be inspected at each SERVICE 1.

N.B.: Certain specific silencer models are fitted with a purge in their lower section to drain any condensation.

### Flexible Sleeves/Connectors

These accessories require no specific maintenance. Inspections should be integrated into SERVICE 1 operations.

These accessories cannot be repaired.

If a sleeve/connector is ripped, replace the pair of sleeves simultaneously (inlet and exhaust), as their life expectancy is similar, to avoid the risk of having to repeat the intervention at short intervals.

### Vibration Isolators (rubber or spring-mountings)

These accessories require no specific maintenance. Inspections should be integrated into SERVICE 1 operations.

These accessories cannot be repaired.



**Vibration Isolators are to be replaced a complete set at a time to avoid interfering with the vibrational behaviour of the equipment.**

### Other accessories

Concerning, in the main, electronic components (sensors or data acquisition systems) used to monitor the system.

See Manufacturer's Manual.

## DIAGNOSTICS

The points covered in this section represent the most frequently encountered problems during normal industrial use. This list is in no way exhaustive. If in doubt as to the type of problem, contact our Support Department.

<b>Symptoms</b>	<b>Probable Cause</b>	<b>Possible solution</b>
The motor does not start when energised	<ul style="list-style-type: none"> <li>- Faulty electrical supply</li> <li>- Faulty cable</li> </ul>	<ul style="list-style-type: none"> <li>- Check supply and cabling</li> <li>-</li> </ul>
The ventilator runs backwards	<ul style="list-style-type: none"> <li>- Inverted phase connection</li> </ul>	<ul style="list-style-type: none"> <li>- Invert two phases</li> <li>- See frequency Inverter (VFD) manual – if available.</li> </ul>
The ventilator turns but the current being used is high – no suspect noises.	<ul style="list-style-type: none"> <li>- One phase missing</li> </ul>	<ul style="list-style-type: none"> <li>- Check supply and cabling</li> </ul>
The ventilator does not turn and the current used is high or the power supply cuts out	<ul style="list-style-type: none"> <li>- Obstacle blocking the turbine wheel</li> <li>- Motor U/S</li> </ul>	<ul style="list-style-type: none"> <li>- Check for foreign objects around the turbine wheel</li> <li>- Remove the turbine wheel and ensure the motor turns freely</li> </ul>
The ventilator turns over but the motor heats up or the power supply cuts itself off – no suspect noise.	<ul style="list-style-type: none"> <li>- Ventilator peak settings too high</li> </ul>	<ul style="list-style-type: none"> <li>- Carry out aerodynamic flow and pressure measurements at the ventilator terminals</li> <li>- Add a pressure drop to the aerodynamic circuit</li> </ul>
Constant metallic noise when running	<ul style="list-style-type: none"> <li>- Contact between turbine wheel and housing</li> <li>- Motor bearings U/S</li> </ul>	<ul style="list-style-type: none"> <li>- Adjust the housing</li> <li>- Change the motor bearings</li> </ul>
Ventilator permanently vibrating at the <b>wheel</b> rotation frequency – no suspect noises	<ul style="list-style-type: none"> <li>- Rotor unbalanced</li> </ul>	<ul style="list-style-type: none"> <li>- Check for the presence of balance weights on the turbine wheel.</li> <li>- Rebalance the wheel after cleaning.</li> </ul>
Ventilator permanently vibrating – metallic noise	<ul style="list-style-type: none"> <li>- Motor bearings U/S</li> </ul>	<ul style="list-style-type: none"> <li>- Change the noisy bearings</li> </ul>
Ventilator vibrates and pulsing noise heard	<ul style="list-style-type: none"> <li>- Aerodynamic surge – Aerodynamic circuit has too high a pressure drop for the ventilator</li> </ul>	<ul style="list-style-type: none"> <li>- Disconnect the inlet or outlet and restart If the symptoms disappear, replace the ventilator with another type or re-design the aerodynamic circuit.</li> </ul>



